

Referencia:	caudal max.	A	B	C	D	E	potencia	voltaje	Ø ventilador	superficie
TP-10	50	400	440	290	200	3/4	10w	220v	250	3,4m ²
TP-15	80	490	525	355	255	3/4	16w	220v	300	5,5m ²
TP-20	100	590	650	425	425	1"	185w	220v	350	12m ²
TP-25	130	660	710	470	450	1"	185w	220v	400	16m ²
TP-10V	50	400	440	290	200	3/4	10w	12v	250	3,4m ²
TP-15V	80	490	525	355	255	3/4	16w	12v	300	5,5m ²
TP-10 2V	50	400	440	290	200	3/4	10w	24v	250	3,4m ²
TP-15 2V	80	490	525	355	255	3/4	16w	24v	300	5,5m ²
TP-20 400V	100	590	650	425	425	1"	185w	400v	350	12m ²
TP-25 400V	130	660	710	470	450	1"	185w	400v	400	16m ²

INTERCAMBIADORES ACEITE-AGUA 1 PASO

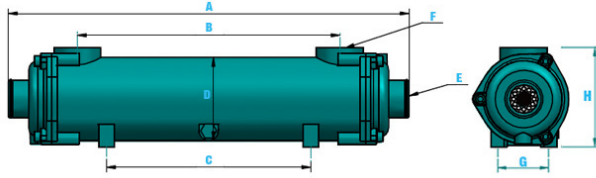

SERIE A

Referencia	Dimensiones m/m								Para motor de potencia (Kw)
	A	B	C	D	E	F	G	H	
TP-A1-MBR	195	72	38	86	50 - 58 - 1 1/2"	3/4"	53	115	80
TP-A2-MBR	263	142	106	86	50 - 58 - 1 1/2"	3/4"	53	115	120
TP-A3-MBR	349	228	192	86	50 - 58 - 1 1/2"	3/4"	53	115	160
TP-A4-MBR	448	326	290	86	50 - 58 - 1 1/2"	3/4"	53	115	200
TP-A5-MBR	576	454	418	86	50 - 58 - 1 1/2"	3/4"	53	115	240
TP-A6-MBR	720	593	557	86	50 - 58 - 1 1/2"	3/4"	53	115	280

SERIE B

Referencia	Dimensiones m/m								Para motor de potencia (Kw)
	A	B	C	D	E	F	G	H	
TP-B1-MBR	276	123	109	108	58 - 1 1/2" - 2"	1"	77	135	140
TP-B2-MBR	355	205	190	108	58 - 1 1/2" - 2"	1"	77	135	180
TP-B3-MBR	452	302	289	108	58 - 1 1/2" - 2"	1"	77	135	240
TP-B4-MBR	587	437	422	108	58 - 1 1/2" - 2"	1"	77	135	300
TP-B5-MBR	730	580	566	108	58 - 1 1/2" - 2"	1"	77	135	360

SERIE C

Referencia	Dimensiones m/m								Para motor de potencia (Kw)
	A	B	C	D	E	F	G	H	
TP-C1-MBR	385	182	92	130	58 - 1 1/2" - 2 1/2"	1 1/4"	78	155	260
TP-C2-MBR	490	287	191	130	58 - 1 1/2" - 2 1/2"	1 1/4"	78	155	300
TP-C3-MBR	610	412	320	130	58 - 1 1/2" - 2 1/2"	1 1/4"	78	155	360
TP-C4-MBR	757	556	465	130	58 - 1 1/2" - 2 1/2"	1 1/4"	78	155	480
TP-C5-MBR	935	733	643	130	58 - 1 1/2" - 2 1/2"	1 1/4"	78	155	540
TP-C6-MBR	1350	1146	1055	130	58 - 1 1/2" - 2 1/2"	1 1/4"	78	155	600

SERIE D

Referencia	Dimensiones m/m								Para motor de potencia (Kw)
	A	B	C	D	E	F	G	H	
TP-D1-MBR	535	270	106	162	DN-80	1 1/2"	120	190	480
TP-D2-MBR	667	397	233	162	DN-80	1 1/2"	120	190	600
TP-D3-MBR	813	546	381	162	DN-80	1 1/2"	120	190	940
TP-D4-MBR	991	722	558	162	DN-80	1 1/2"	120	190	1250
TP-D5-MBR	1193	930	762	162	DN-80	1 1/2"	120	190	1600
TP-D6-MBR	1403	1132	967	162	DN-80	1 1/2"	120	190	2000

SERIE E

Referencia	Dimensiones m/m								Para motor de potencia (Kw)
	A	B	C	D	E	F	G	H	
TP-E1-MBR	708	372	240	198	DN-100	2"	120	230	480
TP-E2-MBR	851	513	382	198	DN-100	2"	120	230	600
TP-E3-MBR	1031	696	563	198	DN-100	2"	120	230	940
TP-E4-MBR	1231	901	763	198	DN-100	2"	120	230	1250
TP-E5-MBR	1441	1102	967	198	DN-100	2"	120	230	1600
TP-E6-MBR	1741	1406	1270	198	DN-100	2"	120	230	2000

SERIE F

Referencia	Dimensiones m/m								Para motor de potencia (Kw)
	A	B	C	D	E	F	G	H	
TP-F1-MBR	765	330	236	278	DN-150	3"	180	325	940
TP-F2-MBR	907	476	382	278	DN-150	3"	180	325	1200
TP-F3-MBR	1089	654	560	278	DN-150	3"	180	325	1600
TP-F4-MBR	1395	860	761	278	DN-150	3"	180	325	1850
TP-F5-MBR	1500	1065	966	278	DN-150	3"	180	325	2000
TP-F6-MBR	1805	1368	1270	278	DN-150	3"	180	325	2300

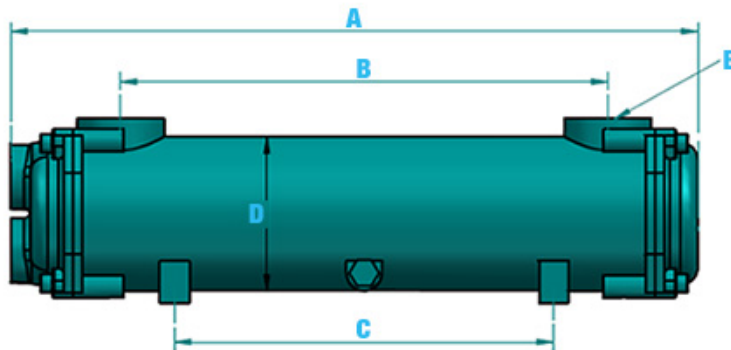

INTERCAMBIADORES ACEITE-AGUA 2 PASOS

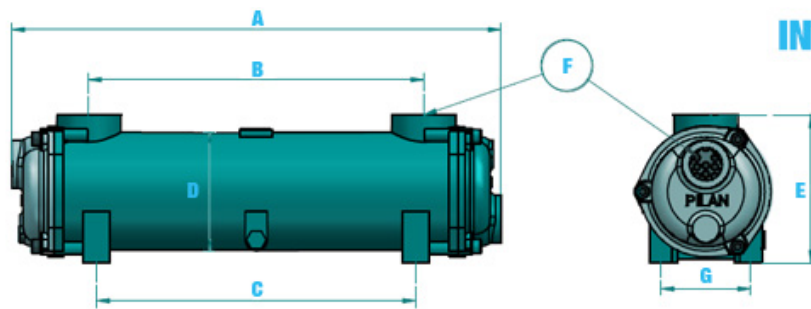
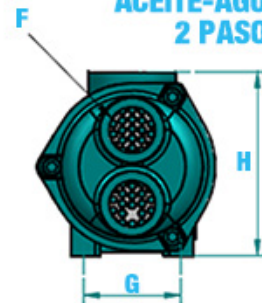

INTERCAMBIADORES ACEITE-AGUA 3 PASOS

INTERCAMBIADORES MOTORES MARINOS

GUASCOR

Referencia	Motor
15.20.005 agua	E-318
15.20.408 agua	E-318TA2
15.20.004 agua	E-212
16.20.102 agua	F-180
201.707. aceite - 1725012	9028-9140
201.709 agua - 1720061	9100/5/9/9222
201.710 agua - 1720062	9156
201.711 aceite - 1725014	9130/35-R-240/300/360
201.712 agua	9140
201.713 agua - 1720064	9130-9135
541.387 aceite	9109/9
582.871 aceite	9109/9
643.644 aceite	9156
114 ø x 495 mm. agua	COMET 1090
114 ø x 285 mm. agua	9109
145,5 ø x 378 mm. agua	9109
145,5 ø x 505 mm. agua	9109
95 ø x 505 mm. agua	
95 ø x 376 mm. agua	

INTERCAMBIADORES COMPLETOS

Referencia GUASCOR	Ref. PILAN
7673471	TP-E2 VT
7673469	TP-E2 BRVT
7673472	TP-E3 BRVT
7673474	TP-E4 BRVT
7673475	TP-E5 BRVT
7673476	TP-F3 BRVT
7673536	TP-C2 MBR 1" 1/2

HACES TUBULARES

Referencia	Ref. PILAN
7673487	TP-E2 HZM
7673497	TP-E3 HZM
7373498	TP-E4 HZM
7673501	TP-E5 HZM
7673502	TP-F3 HZM
7673552	TP-C2 HZM

BAUDOIN

Motor	Referencia	Referencia
12P-15 agua		15.03138.OG
6P-15-2 agua	(3 Taladros)	15.03065
12P-15-2 aceite	1504906	13.61.701
8P-15 agua		13.61.670
6P-15 agua	(4 Taladros)	14.23010
6P-15 aceite		13.61.701
DK-2 agua		22.120
DK-3 agua		22.120
DK-4 agua		22.121
DK-6 agua		21.932
DNP-12 agua	1220039	61.653
DNP-8 agua	1220038	61.670
DNP aceite	1225031	61.604
DNP-6 agua		51.652
6P-15 agua	1199041	51.652
DP-8 agua		61.611
DP-12 agua		61.625
Reductora		55.228
Reductora IRS		61.602

REDUCTORAS BORG-WARNER

Longitud de Haz	Longitud Total	Rosca
5" - 138 m/m	207 m/m	3/8
9" - 238 m/m	309 m/m	3/8
12" - 320 m/m	385 m/m	3/8

Motor	Referencia	Largo	Roscado	Boca
A-24 INVERSOR	4011322230	315 m/m	14/150	180°
A-26 MODERNO	4011412420	415 m/m	18/150	45°
A-26 INVERSOR	4011320520	415 m/m	14/150	180°
C-24 MODERNO	4011412520	415 m/m	18/150	45-136°

PERKINS

Motor	Dimensiones
6354-6354-T agua	113,7ø x 495 m/m
6354-6354-T aceite	80ø x 286 m/m
6354-6354-T reductora	80ø x 213 m/m
Perkins 80 CV aceite	79ø x 250 m/m
4236 agua	114ø x 425 m/m
	114ø x 445 m/m
4236 aceite	80ø x 211 m/m
	60ø x 600 m/m
	102ø x ø90 x 478 m/m
Sole Agua	100ø x 346 m/m
Sole Agua	100ø x 395m/m
	95ø x 376 m/m
	95ø x 420 m/m

OTROS HACES TUBULARES USUALES

ø150 x 400 m/m
ø114 x 420 m/m
ø114 x 495 m/m
ø100 x 346 m/m
ø90 x 230 m/m
ø90 x 111 m/m
ø80 x 984 m/m
ø80 x 286 m/m
ø76 x 280 m/m
ø76 x 270 m/m
ø76 x 265 m/m
ø76 x 260 m/m
FORD-ETI ø114 x 505 m/m
FORD 2704 ET ø76 x 505 m/m
TALBOT ø90 x 230 m/m

VOLVO

Motor	Dimensiones
TAM 120 aceite	114ø x 236 m/m
	177,5ø x 505 m/m
TAMD 120 A/B	235ø x 220ø x 1018 m/m
TMD 31 A aceite	105ø x 86ø x 464 m/m

REDUCTORAS MASSON

Referencia	A	B	C	D	E	F	Largo del haz
TP-A2M-BR	282 m/m	138 m/m	102 m/m	86	ø 45 m/m	3/4	76 ø x 191 m/m
TP-A3M-BR	369 m/m	225 m/m	190 m/m	86	ø 45 m/m	3/4	76 ø x 278 m/m
TP-A4M-BR	467 m/m	326 m/m	288 m/m	86	ø 45 m/m	3/4	76 ø x 376 m/m

SCANIA Y PEUGEOT

Motor	Dimensiones
XUD9 agua	ø90 x 232 m/m
XD3P T agua	ø100 x 345 m/m
XD3P agua	ø60 x 610 m/m